

# Rc-Help

**Your Rc Information Source!**

12.7cm 5in.

Print this page first and check this scale!  
Do Not Use Page scaling

If you need any help building the Rc-Help Trainer, Please visit the link below. We have a full line of videos to help you get into the air!

<http://www.rc-help.com/content.php/304-rc-help-trainer-airplane>

Motor: 60g 1000kv 3s (I use the 2215-1300 Exceed Rocket motor)

ESC: Exceed 30a (Could go 40a to be safe)

Battery: 2200mah 3s 30c

Prop: 10x6 - 11x5.5

Servos: T-Pro 9g Blue

Control Rod: Dubro .047"

Control Horn: Dubro Small

5in.  
12.7cm

# RC #3.1 Trainer

You can use these plans with a landing gear. This is use a skewer in the rudder as the tail wheel. Below location of the main gear. Keep it forward of the Ce inch. But no farther forward than the top of the wir

Landing Gear  
Location

Red Lines are FOLDS. This is where you will fold the plane over to  
Blue Lines are 45° angle cuts. Cut a 45° angle either towards the  
Green Lines are for a CREASE. Use a ruler, spatula or other item to

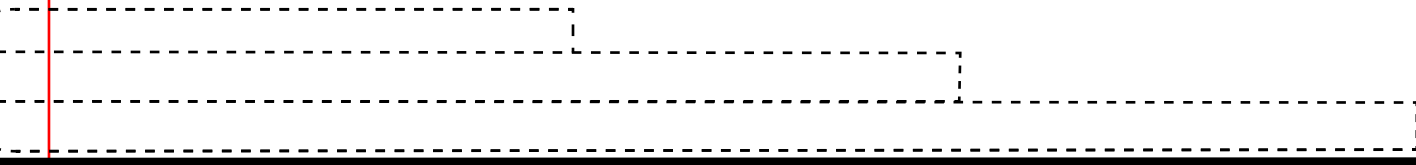

○ Backup the skewer holes with another sheet of foamboard ○

Red Dotted line is a hinge  
Solid Blue Line is Carbon Spar  
Solid Black Line is cut line

This is a tail dragger, and you can  
Below is the  
the Center Of Gravity by atleast an  
the windshield.



These holes are for the servo mount.  
Dotted line is the second piece you cut  
try to only cut the inside and leave outside intact  
**DO NOT CUT DOTTED LINE**  
**REFERENCE ONLY**

ing Gear  
ation

over to make a 90° bend  
wards the red line, or to the outside of the plane. With this sheet laid out, all 45° cuts will be on the same side.  
r item to press into the foamboards so it's easier to bend. Pay attention to which way you need to bend the foam and crease on the correct side!

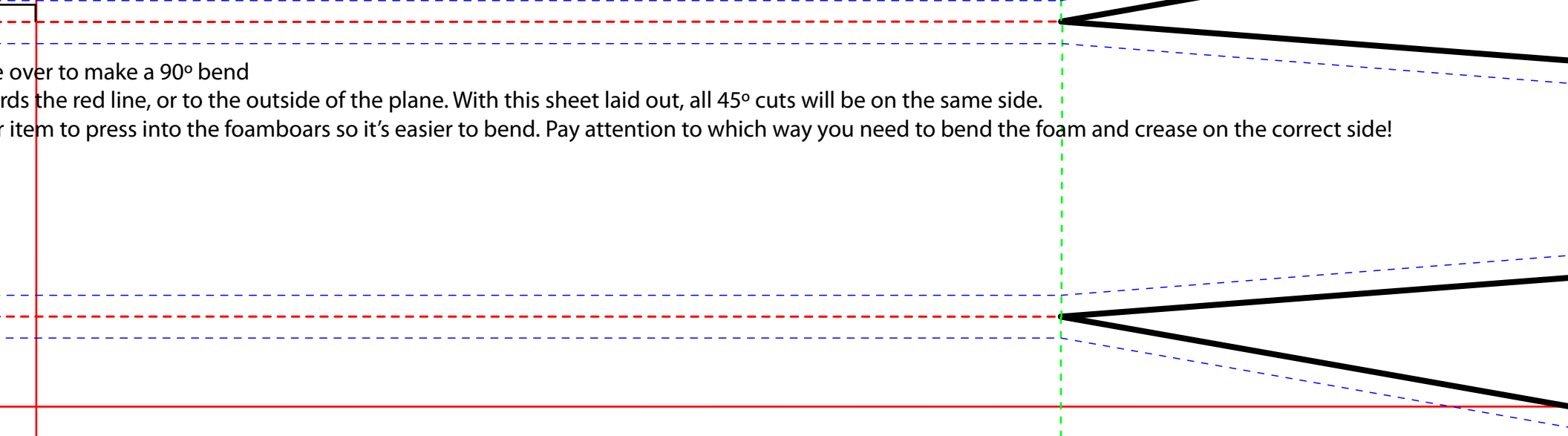

The elevator will now slide into the slot you see in the fuselage. There are marks on the elevator here on the plans to show how to line it up. The gray mark on the elevator should line up with the outside of the fuselage when mounted. There is 2° of built in up angle in the elevator if you cut the plans exactly straight. This will help with slow flight but may make the plane nose up when going fast.

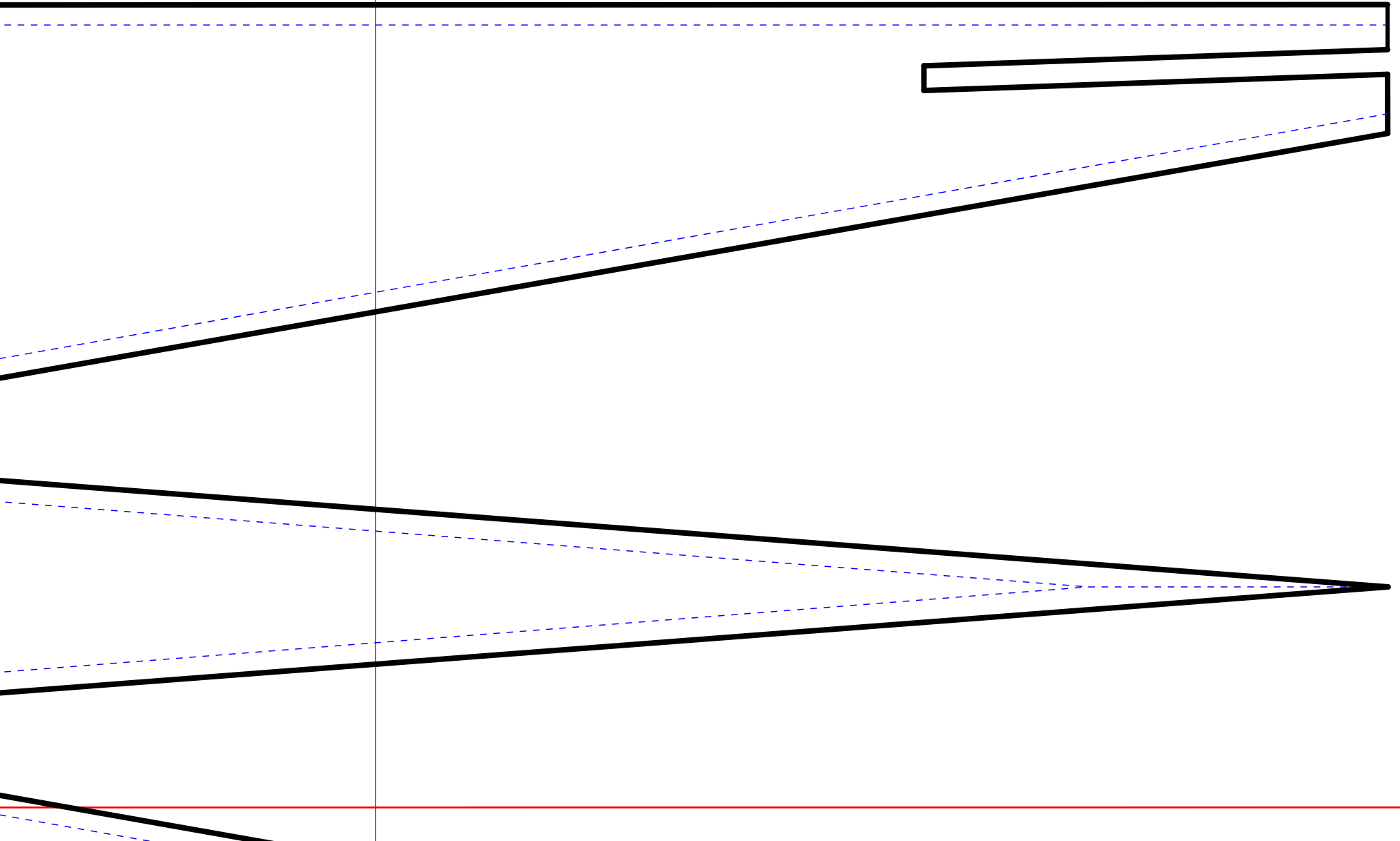

This is the new battery tray. You will crease this and insert it into the nose of the fuselage. Care should be taken as this will be your primary weight for CoG. This will not only secure your battery, but will also help protect it if you crash nose first from the motor bolts. It should look like the image below once bent from the side. Make sure to fit this to YOUR battery. The crease guides are just an example.

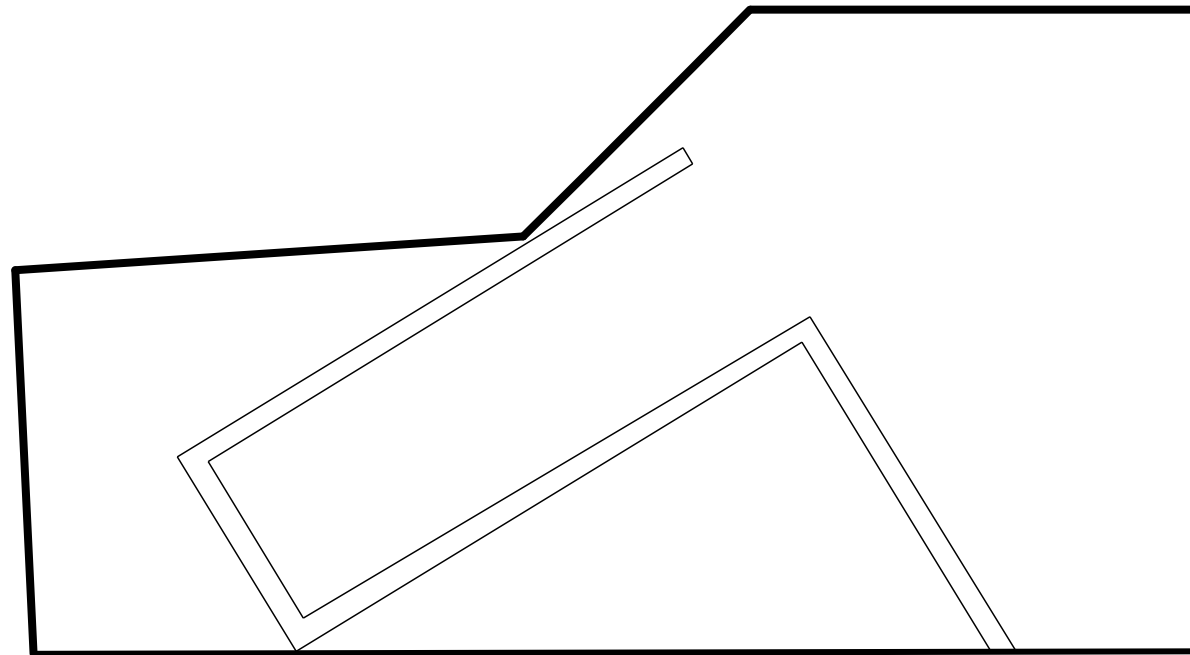
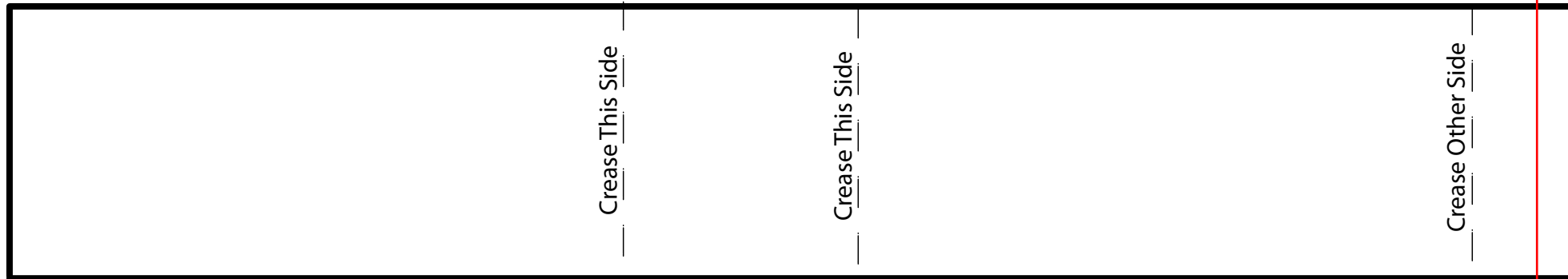

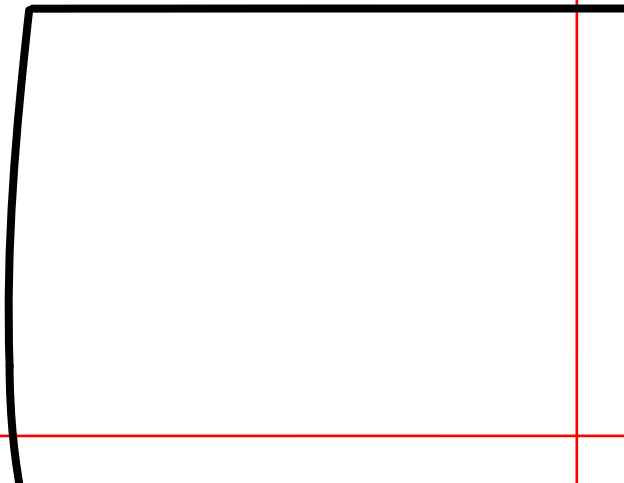
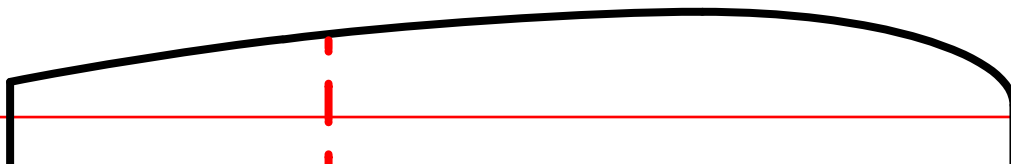
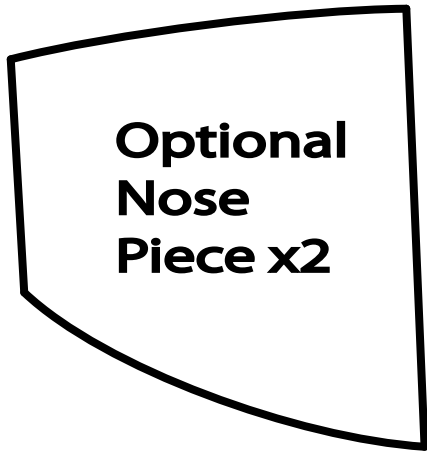
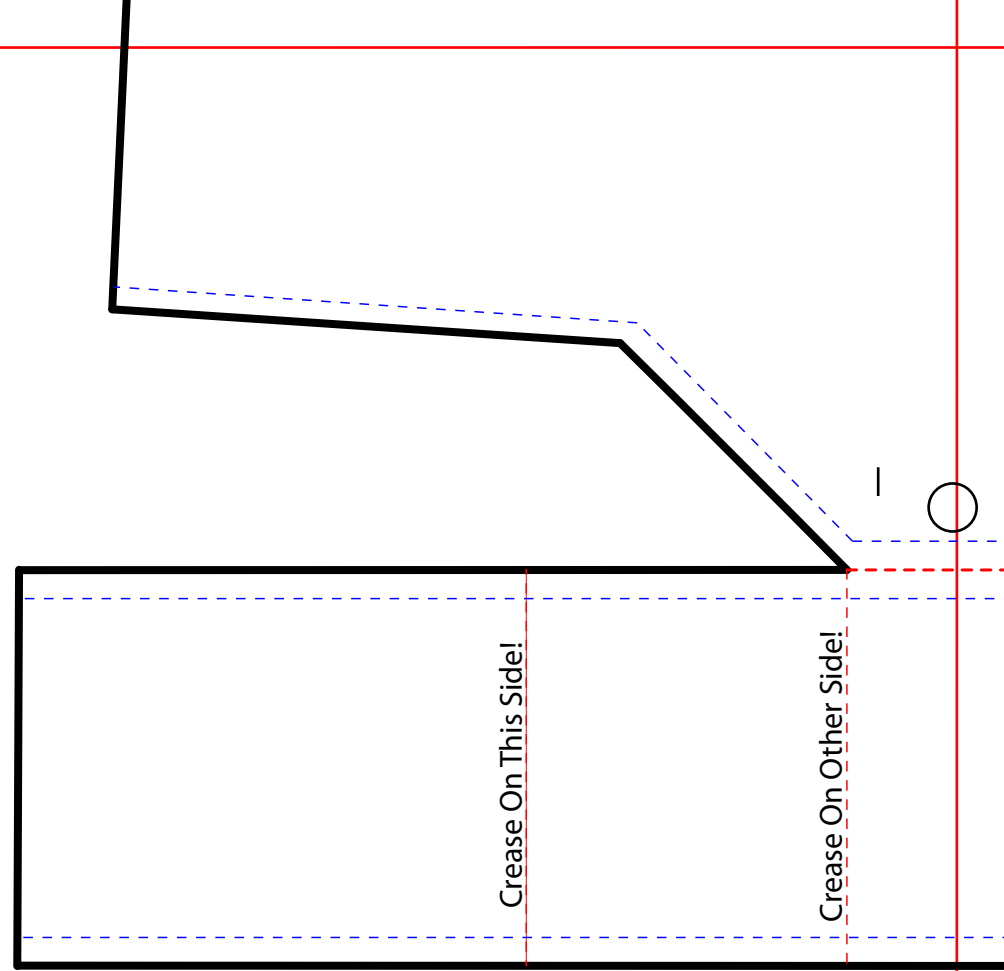
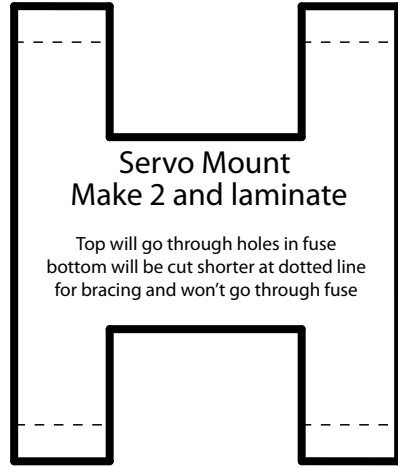
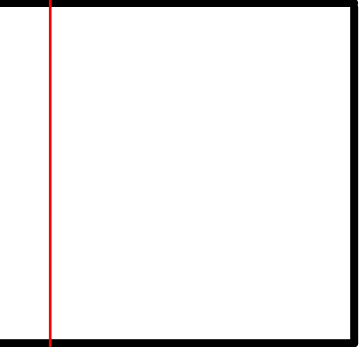

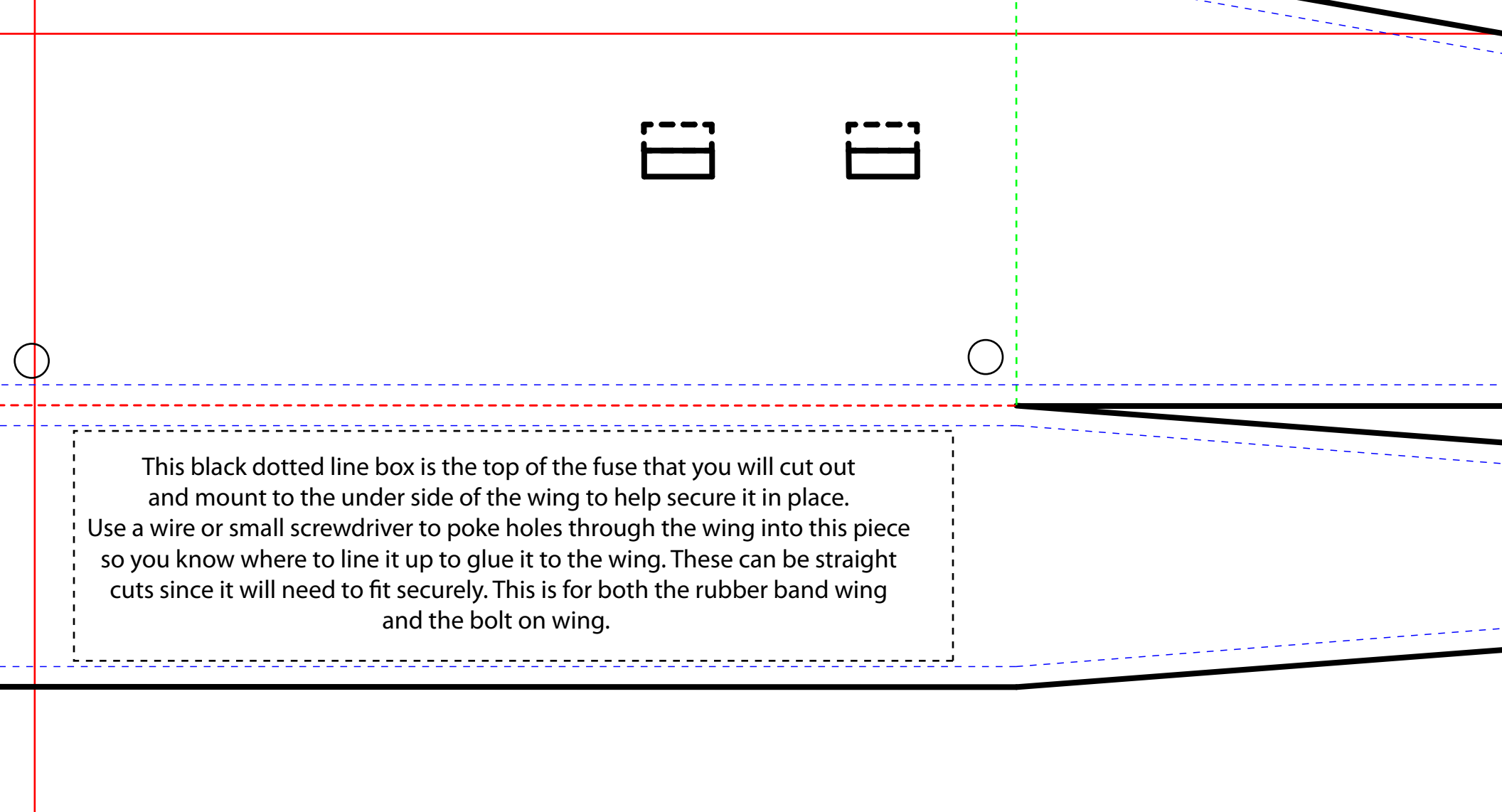
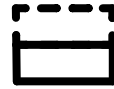
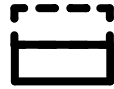

This black dotted line box is the top of the fuse that you will cut out and mount to the under side of the wing to help secure it in place. Use a wire or small screwdriver to poke holes through the wing into this piece so you know where to line it up to glue it to the wing. These can be straight cuts since it will need to fit securely. This is for both the rubber band wing and the bolt on wing.

# Top KFm

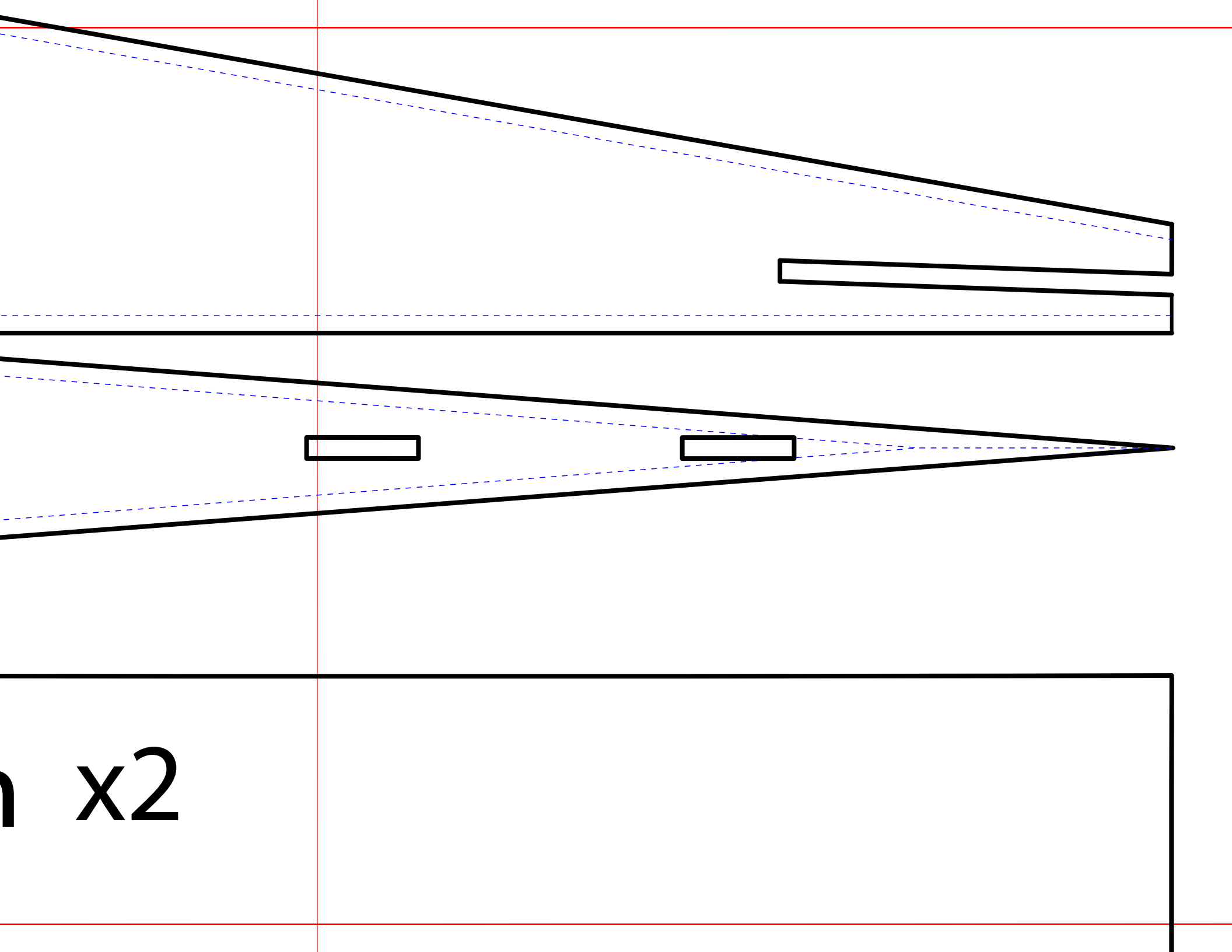

x2



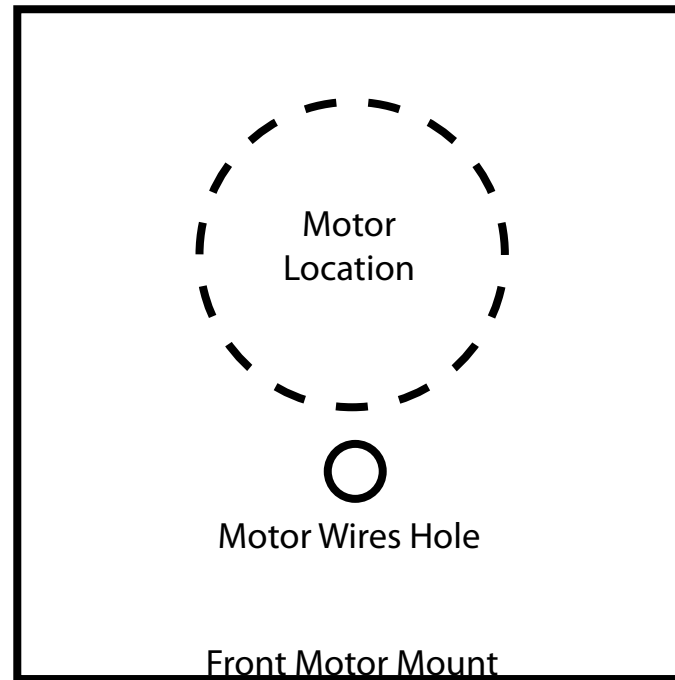

Peel both layers of paper off the foamboard, and glue to the front of the plane fuse. Trim off excess.

or

Mount 1/8" plywood on front with hot glue for mounting the motor to. Blind Nuts are very handy. We use 4-40 size screws.

Round Circle is Aprox Location of motor.

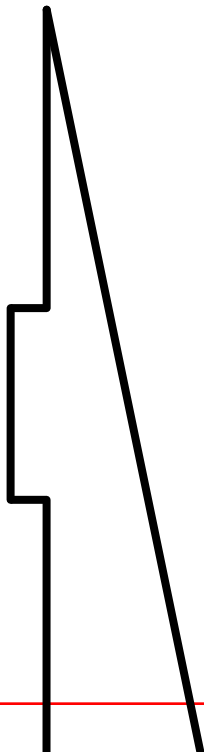

Cut and remove paper t

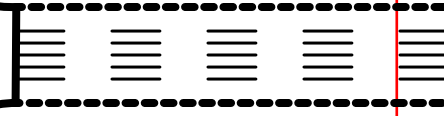

When building this  
about 7° of dihedral.  
on the inside of the  
two wing halves toge  
approx location mark  
fuse under the wing a  
center of the wing. T  
be the width of the t  
than the chord of th  
place with the

Solid Blue Line is a Carbon Spar if needed to support the elevator.



Red Dotted Line is

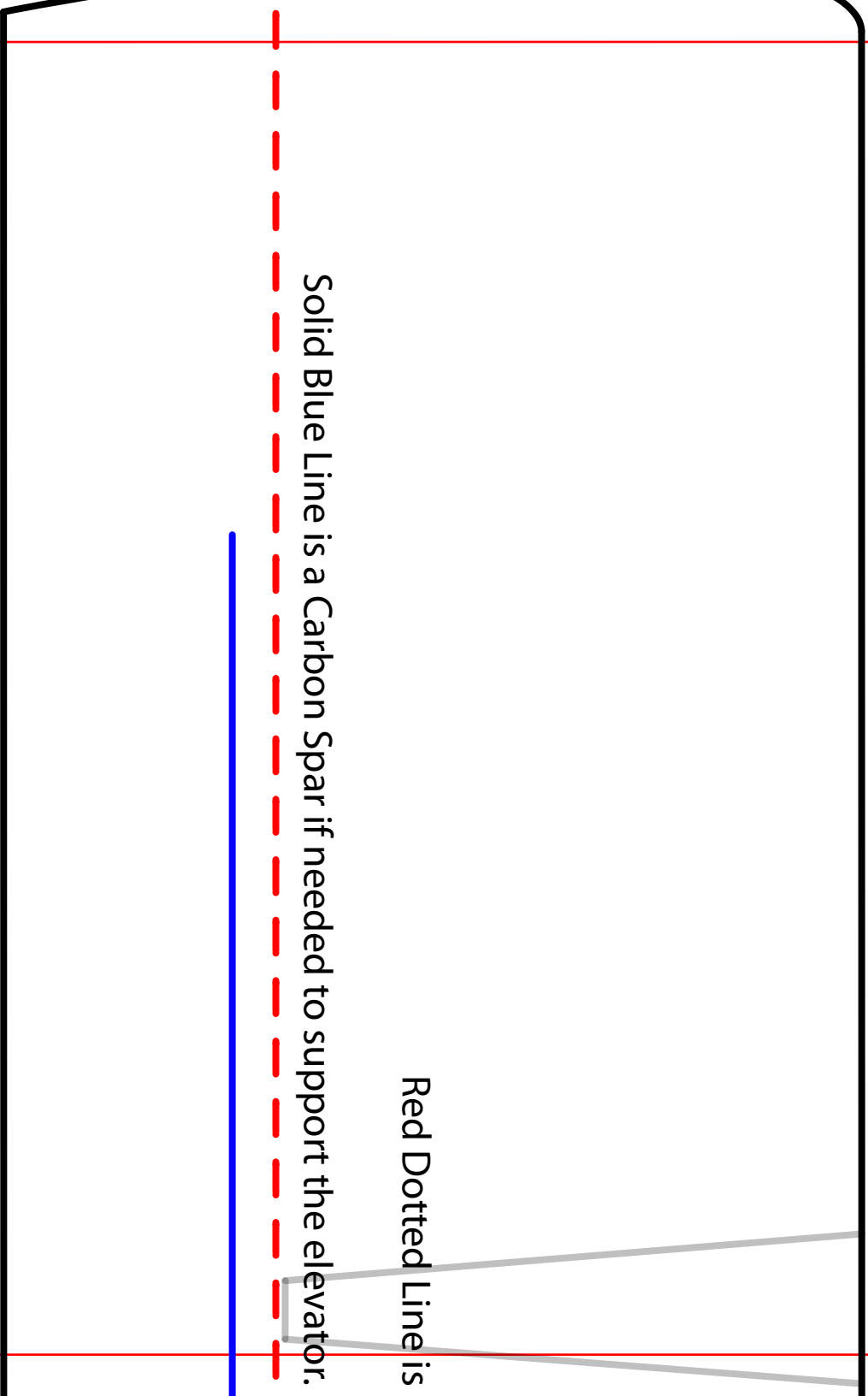

paper from foamboard on ONE SIDE in dashed area. Lay center kfm on top of Main Wing and fold this piece over the

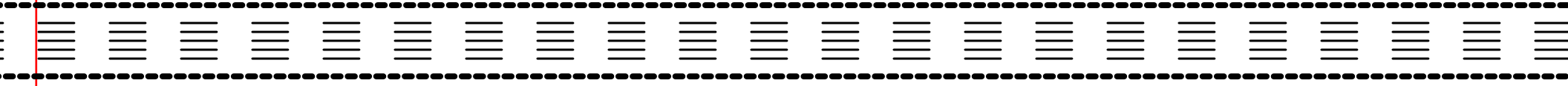

g this wing for stability, you will want  
edral. Make sure you cut the 3.5° angle  
f the wing very straight. Then glue the  
s together. Place wing on top of fuse in  
marked above. Cut out the top of the  
wing and glue that piece on the bottom  
ng. The cutout part of the fuse should  
f the top fuse piece, but a little shorter  
of the wing. This will hold the wing in  
h the help of the rubber bands.

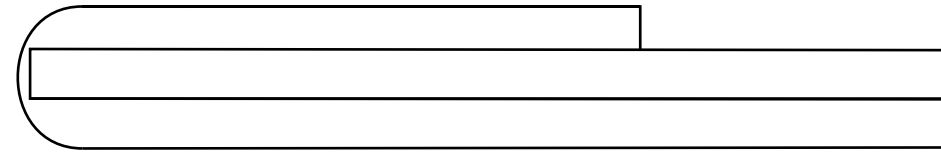

This is the side profile of the Kfm3 wing. As you can see, the center s  
top and bottom pieces giving you a smooth leading edge without c  
trailing edge for proper lift.

Aprox location of Aileron Servo. Mount in botton  
sheet of foam, cut all the way through. Servo will  
be glued to the center sheet of foam.



# Main

Sides of Aileron

Can be made with aileron going all the way across the wing instead of  
Just don't cut the slot between the aileron and the flap.

Red Dotted Line is the Aileron

for the center piece. The bare foam where you removed the paper should be against the center airfoil.

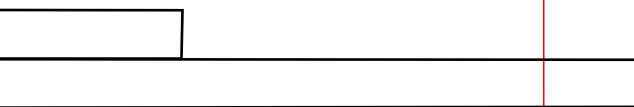
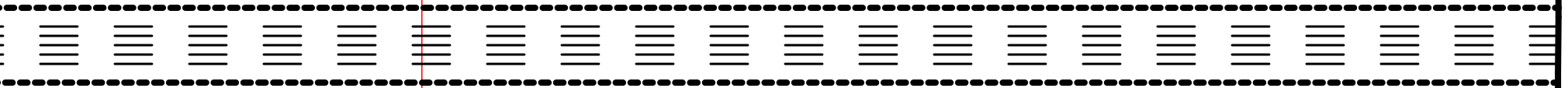

center section will be folded between the  
without cutting. Leave the 90\* angle on the  
lift.

# in Wing x2

aileronons should have 1/16" gap

ead of running a flap.

eron Hinge

**An easy way to set your dihedral is to put a soda can on it's side under one side of the wing while the other wing is flat on the table. This will raise the wing tip up about 2.5". Remember, half the wing flat, the other half with the tip sitting on the soda can.**

Aprox location of Flap Servo. Mount in botton sheet of foam, cut all the way through. Servo will be glued to the center sheet of foam. If your not using flaps, this will be the ONLY servo in the wing for the ailerons.



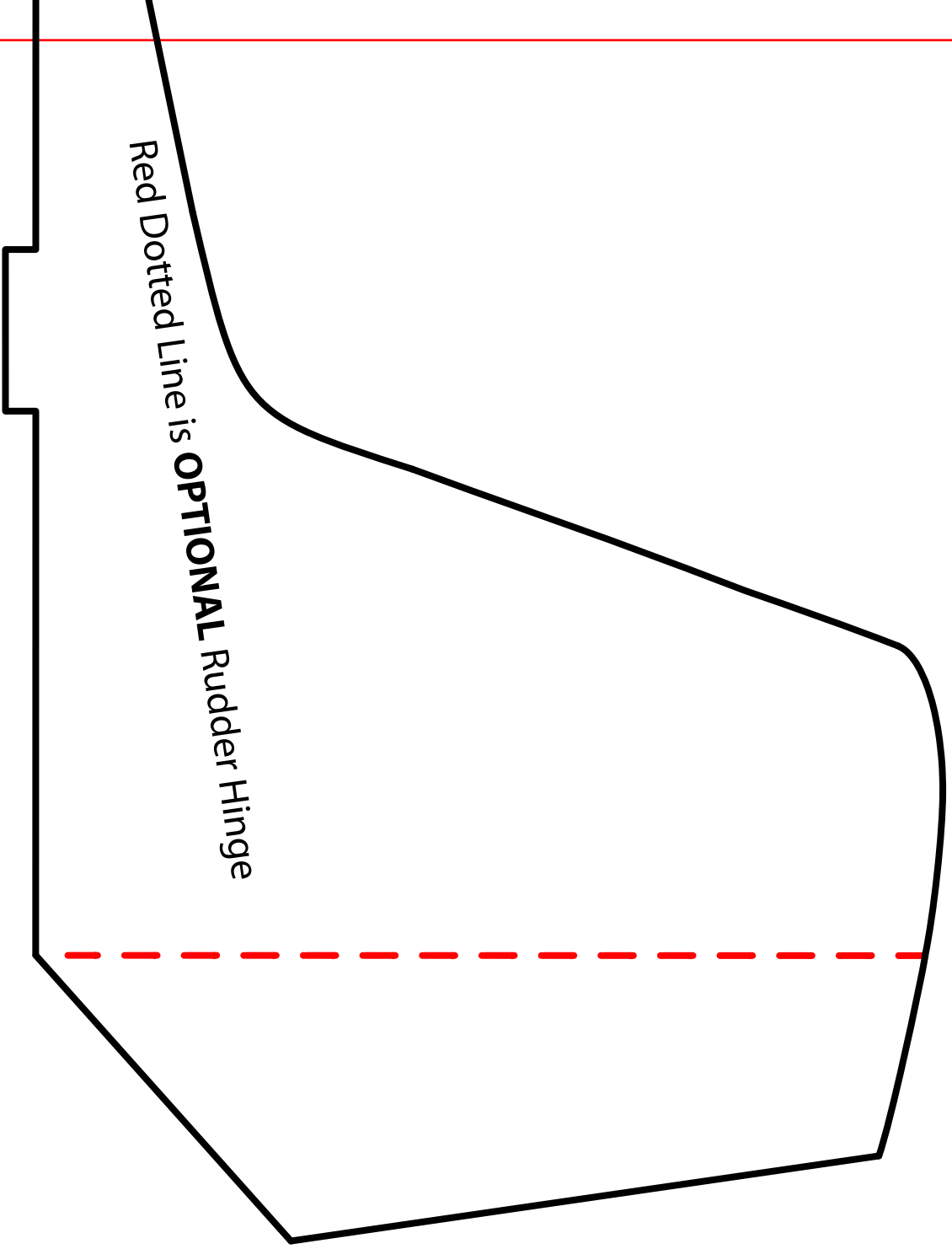

Red Dotted Line is **OPTIONAL** Rudder Hinge

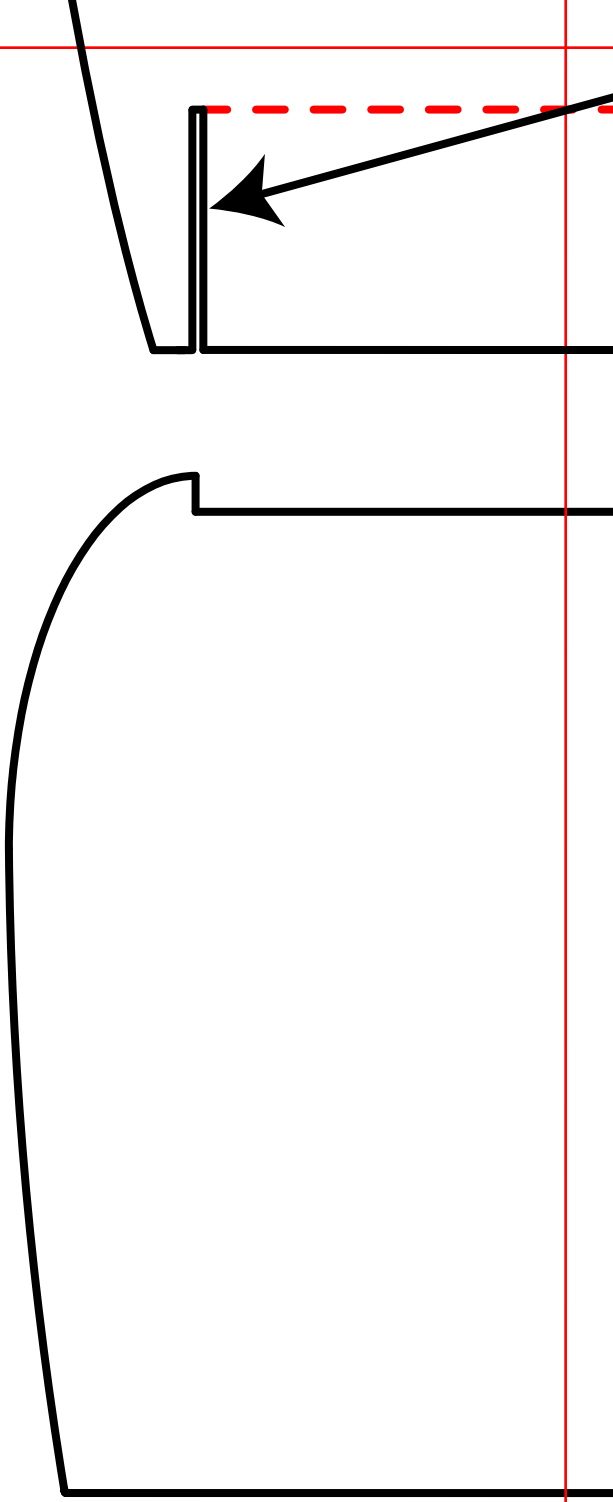

ne is a hinge

ator. This may not be needed with the new elevator design.

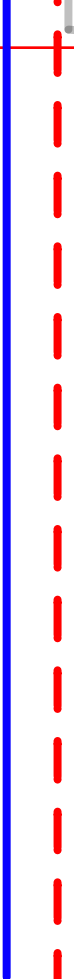

Red Dotted Line is the Aileron

# Aileron

Max deflection 45°

# Flap

# Middle KFr

You can omit this piece if you wish to use the same fold method as shown, there just  
You may need to brace the wing with

Wing Hinge

# Wing lap

If using flaps, make a straight cut down from the top of the wing for the hinge. No need to make a V cut as it only folds one way for landing and take-off.

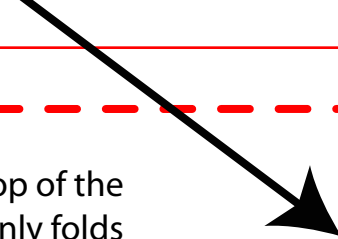

# Kfm x2

to use the kfm2 airfoil. Use the  
just won't be a center kfm3 piece.  
with some 3mm carbon spars.